

# Alcohol and error processing

Clay B. Holroyd and Nick Yeung

Department of Psychology, Princeton University, Princeton, NJ 08544, USA

**A recent study indicates that alcohol consumption reduces the amplitude of the error-related negativity (ERN), a negative deflection in the electroencephalogram associated with error commission. Here, we explore possible mechanisms underlying this result in the context of two recent theories about the neural system that produces the ERN – one based on principles of reinforcement learning and the other based on response conflict monitoring.**

In a recent study, Richard Ridderinkhof and colleagues demonstrated that the consumption of moderate amounts of alcohol can reduce the amplitude of the ‘error-related negativity’ (ERN) [1], a negative deflection in the electroencephalogram (EEG) associated with error commission in speeded response time tasks [2,3]. Because the ERN is commonly thought to be produced by a high-level evaluative system involving the anterior cingulate cortex [4–6], the authors concluded that alcohol consumption leads to impairment in the monitoring of ongoing performance. Importantly, Ridderinkhof *et al.* were careful to rule out two obvious alternative interpretations of their data. The first is that ERN amplitude decreases with decreasing response accuracy [3], so that if the alcohol consumed in the study had been associated with increased error rates then the observed reduction in ERN amplitude could have been attributed to the alcohol-related changes in performance. Ridderinkhof and colleagues avoided this potential problem by ensuring that participants made approximately the same number of errors when given alcohol as when they were given a placebo drink. Second, if alcohol consumption had caused a general reduction in the amplitude of the EEG, then the small ERNs observed in the study would not have been due to a specific impairment in error processing. However, Ridderinkhof and colleagues demonstrated that the alcohol taken by the participants did not reduce the amplitude of the N2, an EEG deflection of comparable size, and thus that the decrease in the size of the ERN did not arise from a general reduction in EEG amplitude. The robustness of these control measures allows us to consider the possible mechanisms by which the performance monitoring system is disrupted by alcohol.

How does alcohol affect the ERN? In general, there are two possibilities. First, alcohol could selectively impair the monitoring system that produces the ERN. Second, alcohol could impair systems involved in stimulus–response processing, thereby degrading the quality of the information upon which the monitoring system depends [7].

Here, we illustrate each of these two possibilities with reference to two recent theories of ERN production [5,6].

## Reinforcement-learning theory of the ERN

According to the reinforcement-learning theory of the ERN [5], a response-monitoring system located in the basal ganglia produces error signals that activate the mesencephalic dopamine system, and the ERN is elicited by the impact of this phasic dopamine activity on the anterior cingulate cortex. Specifically, the theory proposes that a motor control system involving the anterior cingulate cortex generates behavior appropriate to the current external context (Fig. 1a). Simultaneously, a monitoring system located in the basal ganglia predicts the outcome (good or bad) of the response, on the basis of information received from the external environment and an ‘efference copy’ of the response. When the basal ganglia find that events are ‘better’ than expected they produce a ‘good’ error signal, and when they find that events are ‘worse’ than expected they produce a ‘bad’ error signal. These error signals are coded as phasic increases and decreases, respectively, of the tonic activity of the mesencephalic dopamine system [8]. Furthermore, the error signals are carried by the mesencephalic dopamine system to the anterior cingulate cortex, where they reinforce performance on the task at hand [9], and back to the basal ganglia, where they are used to improve the predictions of the monitor [9]. The theory holds that the ERN is produced when a phasic decrease in activity of mesencephalic dopaminergic neurons following error commission disinhibits the apical dendrites of motor neurons in the anterior cingulate cortex, but no ERN is produced when these dendrites are inhibited by a phasic increase in activity of mesencephalic dopaminergic neurons following correct responses.

Importantly, the mesencephalic dopamine system is strongly implicated in alcohol self-administration. Thus, for example, low doses of alcohol activate dopaminergic neurons in the ventral tegmental area [10] and alcohol self-administration is associated with increased dopamine levels in the nucleus accumbens [11]. Furthermore, the reinforcing properties of alcohol appear to depend on dopamine D1 [12] and D2 [13] receptors. In the context of the reinforcement-learning theory of the ERN, such observations suggest that an alcohol-induced impairment of the mesencephalic dopamine system could reduce ERN amplitude in any of several possible ways. For example, increased tonic activity of the mesencephalic dopamine system could lead to increased inhibition of anterior cingulate cortex, resulting in smaller ERNs.

Corresponding author: Clay B. Holroyd (cholroyd@princeton.edu).

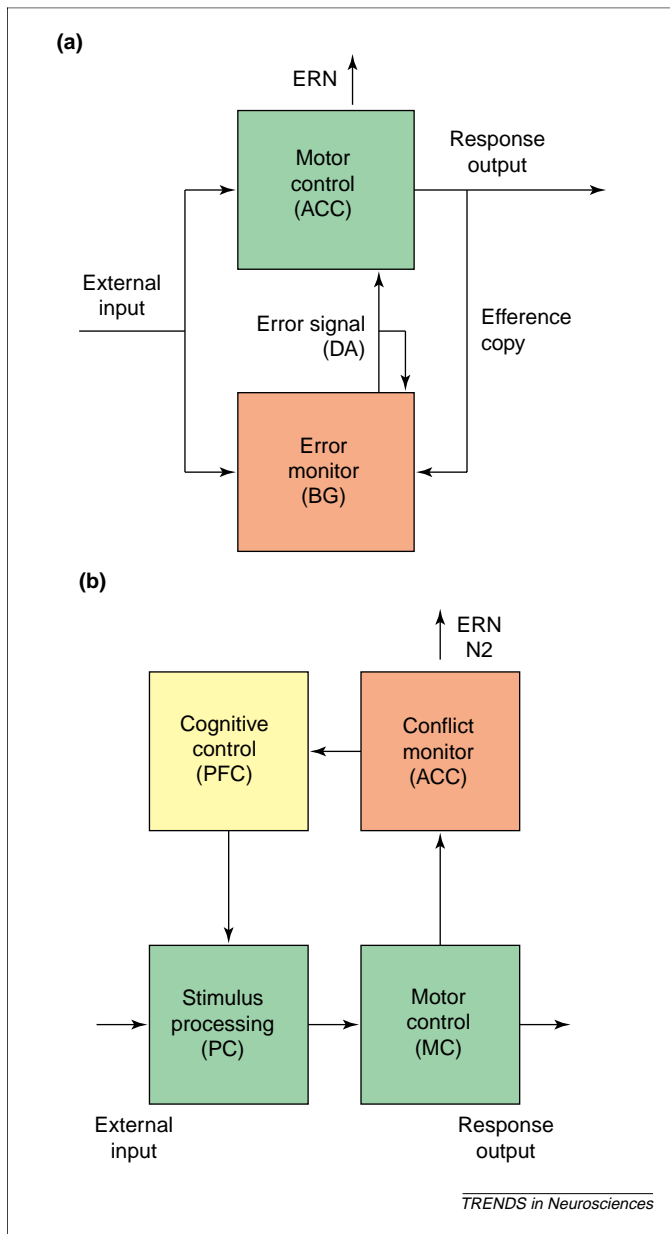

**Fig. 1.** Theories of performance monitoring and the error-related negativity (ERN). (a) Reinforcement-learning theory. (b) Conflict-monitoring theory. Both the reinforcement-learning theory and the conflict-monitoring theory propose mechanisms that monitor the performance (red boxes) of other mechanisms that map external input into response output (green boxes). The conflict-monitoring theory also proposes a separate mechanism for cognitive control (yellow box). The theories hold that the ERN is produced by the anterior cingulate cortex. However, the reinforcement-learning theory proposes that errors are detected in the basal ganglia, whereas the conflict-monitoring theory holds that errors are detected by the anterior cingulate cortex. Alcohol could reduce the amplitude of the ERN directly by disrupting the performance monitoring system, or indirectly by impairing the stimulus–response processes upon which the monitor depends. Abbreviations: ACC, anterior cingulate cortex; BG, basal ganglia; DA, mesencephalic dopamine system; MC, motor cortex; PC, posterior cortex; PFC, prefrontal cortex.

### Conflict-monitoring theory of the ERN

According to a second theory, the ERN reflects the activation of a conflict-monitoring system following error commission [6] (N. Yeung, M. Botvinick and J.D. Cohen, unpublished). Specifically, this theory proposes that the anterior cingulate cortex monitors for response conflict (the simultaneous activation of incompatible response channels) and conveys this information to brain regions involved in cognitive control, such as lateral prefrontal

cortex. A computational model of response selection in the task used by Ridderinkhof and colleagues demonstrates how the ERN can be explained in terms of this theory (Yeung *et al.*, unpublished). In the model (Fig. 1b), conflict is calculated as the product of the activation levels of the competing motor control units associated with the motor cortex. Stimulus processing is characterized by the continuous flow of activity along pathways that map stimulus-related information in the posterior cortex to a corresponding response in motor cortex. Occasionally, noise in the system activates the incorrect response before the stimulus is fully processed, precipitating an error, but continued processing of the stimulus leads to the generation of the correct response (an ‘error correction’). As a consequence, both responses are simultaneously activated for a brief period of time following error commission, resulting in post-response conflict. The anterior cingulate cortex produces the ERN when it detects this conflict.

In contrast to the reinforcement-learning theory of the ERN, which does not make any predictions about the N2, the conflict-monitoring theory holds that the anterior cingulate cortex produces the N2 when it detects pre-response conflict on correct trials [14] (Yeung *et al.*, unpublished). Importantly, Ridderinkhof *et al.* found that alcohol consumption selectively affects the ERN, leaving N2 amplitude unaffected, suggesting that alcohol does not cause a general impairment in conflict monitoring. Instead, the conflict-monitoring theory can explain both the N2 and ERN results in terms of a specific, alcohol-induced impairment in stimulus processing. Such impairment is evident in the data of Ridderinkhof *et al.*: the inebriated participants showed an increase in response times and a reduction in the amplitude of the P3, an EEG deflection sensitive to stimulus categorization (R. Ridderinkhof, unpublished). According to the conflict hypothesis, the ERN is produced when continued stimulus processing after an error leads to activation of the correct response, resulting in post-error conflict. An alcohol-induced impairment in stimulus processing would reduce this activation of the correct response following errors, which would in turn reduce post-error conflict and, hence, reduce the amplitude of the ERN. By contrast, Ridderinkhof *et al.* reported that the behavioral measures of response conflict on correct trials were identical across conditions so that, according to the conflict model, a reduction in N2 amplitude would not be expected.

### Future research

Thus, alcohol consumption could reduce ERN amplitude either directly, by affecting the monitoring system that produces the ERN, or indirectly, by affecting the stimulus processing system upon which the monitoring system depends. A future experiment could decide between these two possibilities. In particular, we envisage a replication of Ridderinkhof *et al.*'s experiment with a new control placebo condition, in which participants respond to degraded stimuli such that their behavioral measures are about the same as in the alcohol condition. If alcohol impairs stimulus processing, but the quality of stimulus processing is matched across conditions, then the participants should produce equally small ERNs in both

conditions. However, if alcohol selectively impairs the monitoring system, then the participants should produce smaller ERNs when inebriated but not when responding to the degraded stimuli. In either case, the results of such a study would extend Ridderinkhof and colleagues' pioneering research on how alcohol consumption affects performance evaluation.

## References

- Ridderinkhof, K.R. *et al.* (2002) Alcohol consumption impairs detection of performance errors in mediofrontal cortex. *Science* 298, 2209–2211
- Falkenstein, M. *et al.* (1990) Effects of errors in choice reaction tasks on the ERP under focused and divided attention. In *Psychophysiological Brain Research* (Brunia, C. *et al.*, eds), pp. 192–195, Tilburg University Press
- Gehring, W.J. *et al.* (1993) A neural system for error detection and compensation. *Psychol. Sci.* 4, 385–390
- Coles, M.G.H. *et al.* (2001) Why is there an ERN/Ne on correct trials? Response representations, stimulus-related components, and the theory of error-processing. *Biol. Psychol.* 56, 191–206
- Holroyd, C.B. and Coles, M.G.H. (2002) The neural basis of human error processing: reinforcement learning, dopamine, and the error-related negativity. *Psychol. Rev.* 109, 679–709
- Botvinick, M. *et al.* (2001) Conflict monitoring and cognitive control. *Psychol. Rev.* 108, 624–652
- Scheffers, M.K. and Coles, M.G.H. (2000) Performance monitoring in a confusing world: error-related brain activity, judgments of response accuracy, and types of errors. *J. Exp. Psychol. Hum. Percept. Perform.* 26, 141–151
- Schultz, W. (2002) Getting formal with dopamine and reward. *Neuron* 36, 241–263
- Sutton, R.S. and Barto, A.G. (1998) *Reinforcement learning: An introduction*, MIT Press
- Gessa, G.L. *et al.* (1985) Low doses of ethanol activate dopaminergic neurons in the ventral tegmental area. *Brain Res.* 348, 201–203
- Weiss, F. *et al.* (1993) Oral alcohol self-administration stimulates dopamine release in the rat nucleus accumbens: genetic and motivational determinants. *J. Pharmacol. Exp. Ther.* 267, 250–267
- Cohen, C. *et al.* (1999) Effects of D1 dopamine receptor agonists on oral ethanol self-administration in rats: comparison with their efficacy to produce grooming and hyperactivity. *Psychopharmacology* 142, 102–110
- Phillips, T.J. *et al.* (1998) Alcohol preference and sensitivity are markedly reduced in mice lacking dopamine D2 receptors. *Nat. Neurosci.* 1, 610–615
- Van Veen, V. and Carter, C.S. (2002) The timing of action monitoring in rostral and caudal anterior cingulate cortex. *J. Cogn. Neurosci.* 14, 593–602

0166-2236/03/\$ - see front matter © 2003 Elsevier Science Ltd. All rights reserved.  
doi:10.1016/S0166-2236(03)00175-9

# Potential roles of insulin and IGF-1 in Alzheimer's disease

Laura Gasparini<sup>1</sup> and Huaxi Xu<sup>2,3</sup>

<sup>1</sup>Nicox Research Institute, Via Ariosto 21, 20091 Bresso, Milan, Italy

<sup>2</sup>The Fisher Center for Research on Alzheimer Disease, The Rockefeller University, 1230 York Avenue, New York, NY 10021, USA

<sup>3</sup>Current address: Center for Neuroscience and Aging, The Burnham Institute, 10901 N. Torrey Pines Road, La Jolla, CA 92037, USA

**Aging is characterized by a significant decline of metabolic and hormonal functions, which often facilitates the onset of severe age-associated pathologies. One outstanding example of this is the reported association of deranged signaling by insulin and insulin-like-growth-factor 1 (IGF-1) with Alzheimer's disease (AD). Recent compelling biological data reveal effects of insulin and IGF-1 on molecular and cellular mechanisms underlying the pathology of AD. This review discusses available biological data that highlight the therapeutic potential of the insulin-IGF-1 signaling pathway in AD.**

In the past few years, several findings have pointed to the crucial role of the insulin and insulin-like-growth-factor 1 (IGF-1) pathway for lifespan regulation in *Caenorhabditis elegans*, *Drosophila*, yeast and, last but not least, mammals [1,2]. This is not surprising considering the importance of insulin and IGF-1 in the regulation of physiological functions such as glucose and energy metabolism and growth. In addition, emerging evidence suggests that insulin and IGF-1 have important functions

in the brain, including metabolic, neurotrophic, neuro-modulatory and neuroendocrine actions [3]. Insulin, IGF-1, their receptors and IGF-1-binding proteins (IGFBPs) are all present in rodent and human brain [4–6]. It is now known that insulin and IGF-1 are actively transported across the blood–brain barrier and possibly even produced locally in the brain [4]. Insulin and IGF-1 share a high degree of structural and functional homology and both bind to, and activate, the receptor of the other, thus sharing several physiological functions. There is evidence that insulin receptors and IGF-1 receptors modulate neuronal activity [7], resulting in the regulation of food intake, energy metabolism, reproduction and, possibly, cognitive functions.

In addition to the physiological activities in the brain, a wealth of data points to a potential role of the insulin-IGF-1 pathway in the pathogenesis of age-related neurodegenerative diseases, such as Alzheimer's disease (AD) [8]. In particular, AD patients show changes in insulin and IGF-1 levels and their response to insulin is defective. AD, the most common form of dementia in the elderly, is characterized by insidious onset with cognitive impairment and inexorable progression. Neuropathological analysis of

Corresponding authors: Laura Gasparini (gasparini@nicox.it), Huaxi Xu (xuh@mail.rockefeller.edu) and (xuh@burnham.org).